

Manufactured and distributed by © 2016 WowWee Group Limited. Product names, designations, and logos are trademarks or registered trademarks of WowWee Group Limited. All rights reserved.

Customer Service Website: <http://wowweezone.com>

We recommend that you retain our address for future reference.

Product and colors may vary.

Packaging printed in China.

**WARNING!** This product is not suitable for children under 3 years because of small parts - choking hazard.

Apple, the Apple logo, iPhone, iPad, iPad mini, iPad Air, and iPod touch are trademarks of Apple Inc., registered in the U.S. and other countries. App Store is a service mark of Apple Inc., registered in the U.S. and other countries.

Android and Google Play are trademarks of Google Inc.

Amazon and Amazon Appstore are trademarks of Amazon.com, Inc.

CAN ICES-3(B)/NMB-3(B)

MADE IN CHINA

#### CAUTION

Changes or modifications not expressly approved by the party responsible for compliance could void the user's authority to operate the equipment.

#### NOTE

This equipment has been tested and found to comply with the limits for a class B digital device, pursuant to part 15 of the FCC rules. These limits are designed to provide reasonable protection against harmful interference in a residential installation. This equipment generates, uses and can radiate radio frequency energy and, if not installed and used in accordance with the instructions, may cause harmful interference to radio communications.

However, there is no guarantee that interference will not occur in a particular installation. If this equipment does cause harmful interference to radio or television reception, which can be determined by turning the equipment off and on, the user is encouraged to try and correct the interference by one or more of the following measures:

- Reorient or relocate the receiving antenna
- Increase the separation between the equipment and receiver
- Connect the equipment into an outlet on a circuit different from that to which the receiver is connected
- Consult the dealer or experienced radio/TV technician for help

This Device complies with Part 15 of the FCC Rules. Operation is subject to the following two conditions:

- (1) This device may not cause harmful interference, and
- (2) This device must accept any interference received, including interference that may cause undesired operation.

This device complies with Industry Canada Licence-exempt RSS-210. Operation is subject to the following two conditions:

- (1) This device may not cause interference, and
- (2) This device must accept any interference, including interference that may cause undesired operation of the device.

For these purposes, the party responsible is:

WowWee USA Inc.  
7855 Fay Avenue, Suite 310  
La Jolla CA, USA 92037  
1-800-310-3033

Frequency band(s) : 2.402 – 2.480 GHz  
Maximum radio frequency power transmitted : -4.89 dBm  
WowWee Group Limited declares that the product [Elmoji™] is in compliance with Directive 2014/53/EU.  
The full text of the EU declaration of conformity is available at the following internet address:  
<http://www.wowwee.com/EUdeclaration.html>

For more indepth instructions, please refer to

<http://wowwee.com/coji>

For warranty information, please visit

<http://wowwee.com/information/warranty>



WowWee Group Limited.

WowWee Canada Inc.

Customer Service:

Item No.:

Age:

Manufactured and distributed by © 2016 WowWee Group Limited.

All Rights Reserved.

Energy Plaza, 301A-C  
92 Granville Road  
T.S.T. East, Hong Kong  
3700 Saint Patrick Street  
Suite 206, Montreal  
QC H4E 1A2, Canada  
<http://wowweezone.com>

2802

3+

## USER MANUAL

### Package Contents:

Elmoji™ x 1  
Quick Start Guide x 1  
User Manual x 1

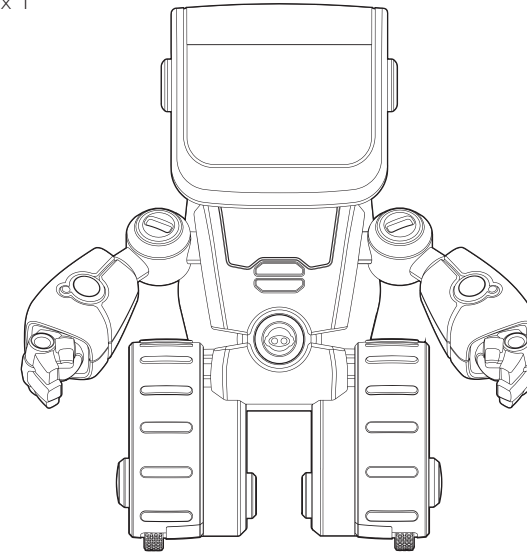

Elmoji™

**WARNING!** This equipment may experience difficulty and/or memory loss when subjected to any electrostatic discharge, radio frequency interference, or sudden power surge/interruption. The user is encouraged to reset the equipment should any of these occur.



WowWee Group Limited  
Energy Plaza, 301A-C  
92 Granville Road  
T.S.T. East, Hong Kong

WowWee Canada Inc.  
3700 Saint Patrick Street  
Suite 206  
Montreal, QC, H4E 1A2, Canada



Please note the following when operating Elmoji™:

- Do not immerse Elmoji™ or any of its parts in water or any other form of liquid.
- Do not drop, throw, or kick Elmoji™ as this may damage mechanical functions.
- Do not leave Elmoji™ unattended near edges from which it could fall.

## BATTERY INFORMATION

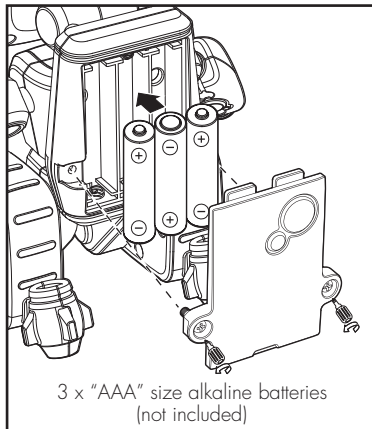

3 x "AAA" size alkaline batteries  
(not included)  
Elmoji™ Battery Diagram/Installation

### Installing or changing batteries in Elmoji™:

1. Lay Elmoji™ down so that the battery compartment faces upwards. Elmoji™ requires 3 x "AAA" size alkaline batteries (not included).
2. Using a Phillips screwdriver (not included) remove the screws on the battery compartment cover.
3. Remove any existing batteries and insert new batteries according to the diagram. Ensure that the positive and negative polarities match the illustrations inside the battery compartment.
4. Replace the battery compartment cover and tighten screws using the screwdriver. Do not over-tighten.

### IMPORTANT BATTERY INFORMATION:

- Use only fresh batteries of the required size and recommended type.
- Do not mix old and new batteries, different types of batteries [standard (Carbon-Zinc), Alkaline or rechargeable] or rechargeable batteries of different capacities.
- Remove rechargeable batteries from the toy before recharging them.
- Rechargeable batteries are only to be charged under adult supervision.
- Please respect the correct polarity, (+) and (-).
- Do not try to recharge non-rechargeable batteries.
- Do not dispose of batteries into fire.
- Replace all batteries of the same type/brand at the same time.
- The supply terminals are not to be short-circuited.
- Remove exhausted batteries from the toy.
- Batteries should be replaced by adults.
- Batteries should be recycled or disposed of as per state and local guidelines.

### LOW BATTERY INDICATORS:

When the batteries grow weak, Elmoji™ will move very slowly. You can also see current battery levels via the Elmoji™ App. When this happens, power OFF and replace all batteries.

## APP COMPATIBILITY

### Apple® iOS and Android™ devices:

Devices must support Bluetooth® Smart (also known as Bluetooth® Low Energy) in order to play. For the latest compatible device list, please visit <http://wowwee.com/devices>

## DOWNLOADING THE APP



### For Apple® Devices:

Go to the App Store™ and search for the WowWee "Elmoji" App. Then, click download.

### For Android™ Devices:

Go to the Google Play™ Store or Amazon Appstore™ and search for the Elmoji™ App. Then, click download.

## CONNECTING TO ELMOJI™ WITH YOUR DEVICE

### To connect Elmoji™ with your device:

1. Turn Elmoji™ ON as instructed in the Quick Start Guide.
2. Open the Elmoji™ App on your device.
3. Follow the on-screen instructions.

## Q & A

- Q:** I cannot access Google Play™ on my Android™ device, how can I download the application?  
**A:** Try downloading the application on the Amazon AppStore™. All WowWee® applications are officially provided there for users who cannot use Google Play™.
- Q:** When I try to download the Elmoji™ app on my Android™ phone, it says it's incompatible with my device.  
**A:** Elmoji™ only works with devices which are Bluetooth® Smart Ready and running compatible operating systems. Generally our toys are expected to be compatible with most Android™ phones or tablets that are Bluetooth® Smart Ready (also known as Bluetooth® Low Energy). The easiest way to test Elmoji™ app compatibility on your Android™ device is to attempt to download the Elmoji™ App. If your device is not compatible, Google Play™ will not allow you to see, download, or install the app. If the app can download, install, and run correctly on your device, we expect full compatibility.
- Q:** My Elmoji™ won't show up in the app when I try to connect.  
**A:** Make sure your Elmoji™ has fresh batteries and is turned on, then close the app and switch Bluetooth® on/off in your device settings. If you're still having problems, try restarting your device completely.
- Q:** My Elmoji™ disconnects often and/or seems to pause or run slow.  
**A:** This is most likely caused by Bluetooth® interference. Ensure that there are no other Bluetooth® devices connected or switched on (especially audio devices), as these can cause interference which can cause issues. If you're still having problems try turning your device's WiFi off to reduce interference.
- Q:** My Elmoji™ turns on, but the screen flashes then switches off and/or Elmoji™ turns off unexpectedly during play.  
**A:** Most likely the batteries are low or flat, try replacing the batteries in Elmoji™.

For more indepth FAQ, please refer to <http://wowwee.com/elmoji>